



JH5442IL7

Description

The JH5442IL7 is a high precision non-isolated buck driver with active PFC, specially designed for universal input offline constant current LED lighting. The driver with on-chip PFC circuit achieves high power factor and low THD. Operating in critical conduction mode, the power MOSFET switching loss is reduced and the inductor is fully utilized.

The JH5442IL7 integrates a 650V power MOSFET. With few external components, the LED output current can be precisely controlled.

The JH5442IL7 utilizes floating ground structure. The inductor current is sensed during the whole switching cycle. So it achieves high precision output current control, and excellent line regulation and load regulation.

The JH5442IL7 are built-in JFET start-up and IC power supply circuit, which enable the system to quickly start, and reduce the external power supply components, achieve smaller volume.

The JH5442IL7 offers rich protection functions to improve the system reliability, including LED open circuit protection, LED short circuit protection, VCC under voltage protection, CS resistor open circuit protection and cycle by cycle current limit. All the protection functions are auto-recovery. The system reliability is further improved by the thermal regulation function. The output current is reduced when the driver is over temperature.

Available in SOP-7 package.

Features

- Built-in JFET start-up and IC power supply circuit, The VCC power supply resistors and power feedback circuits from LED chips are not needed
- Ultra fast system start
- Ultra low operating current
- Active PFC for High Power Factor and Low THD
- Internal 650V Power MOSFET
- $\pm 3\%$ LED Output Current Accuracy
- Excellent Line and Load Regulation
- Critical Conduction Mode Operation
- LED Short/Open Protection
- Current Sensing Resistor Open Protection
- Cycle by Cycle Current Limit
- VCC Under Voltage Protection
- Auto Fault Recovery
- Thermal Regulation Function

Applications

- LED retrofit lamps, Bulb, Spot Light, GU10/E27
- PAR Lamp
- LED String, LED tube
- Other LED Light





JH5442IL7

Typical Application

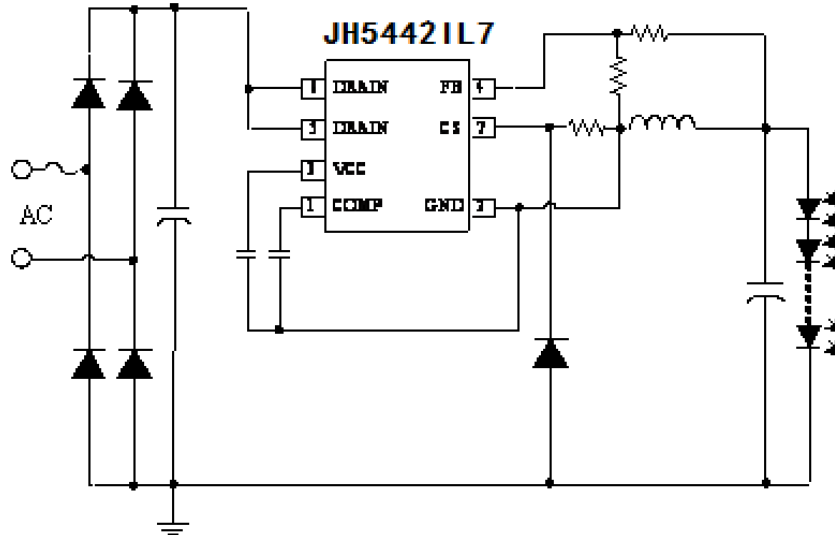

Figure 1. Typical application circuit for JH5442IL7

Ordering Information

Order codes				Marking	Package
Halogen-Tube	Halogen-Free-Tube	Halogen-Reel	Halogen-Free-Reel		
N/A	N/A	N/A	JH5442IL7-LP-AR	JH5442	SOP-7

Pin Configuration and Marking Information

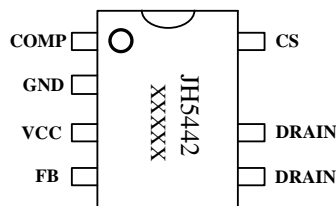

Figure 2. Pin configuration

Pin Definition

Pin No.	Name	Description
1	COMP	Loop Compensation Node. This pin connects a capacitor to GND for stabilization of the control loop, achieving accurate LED current, high Power Factor and low THD.
2	GND	Ground.
3	VCC	Power Supply Pin. Connect a bypass capacitor from this pin to GND.





JH5442IL7

4	FB	Feedback Voltage Input Pin. This pin detects the inductor demagnetization signal and the output voltage.
5,6	DRAIN	Internal HV Power MOSFET Drain.
7	CS	Current Sense Pin. Connect a resistor to GND to sense the inductor current.

Internal Block Diagram

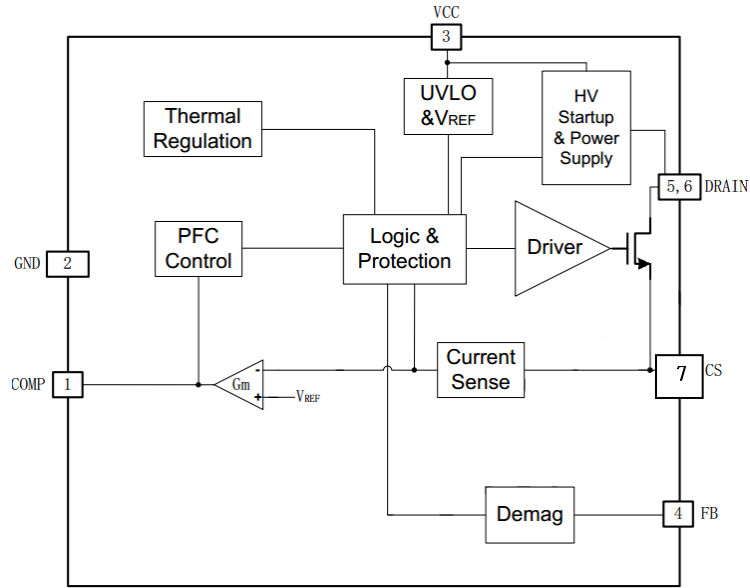

Figure 3. JH5442IL7 Internal Block Diagram

Absolute Maximum Ratings (note1)

Symbol	Parameters	Range	Units
V_{DS}	Internal HV MOSFET Drain to Source voltage	-0.3~650	V
I_{CC_MAX}	VCC pin maximum sink current	20	mA
COMP	Compensation pin voltage	-0.3~6	V
FB	Feedback pin input voltage	-0.3~6	V
CS	Current sense pin input voltage	-0.3~6	V
P_{D_MAX}	Power dissipation (note2)	0.45	W
θ_{JA}	Thermal resistance (Junction to Ambient)	145	°C/W
T_J	Operating junction temperature	-40 to 150	°C
T_{STG}	Storage temperature range	-55 to 150	°C
	ESD (note3)	2	KV

Note 1: Stresses beyond those listed “absolute maximum ratings” may cause permanent damage to the device. Under “recommended operating conditions” the device operation is assured, but some particular parameter may not be achieved. The electrical characteristics table defines the operation range of the device, the electrical characteristics is assured on DC and AC voltage by test program. For the parameters without minimum and maximum value in the EC table, the typical value defines the operation range, the accuracy is not





JH5442IL7

guaranteed by spec.

Note 2: The maximum power dissipation decrease if temperature rise, it is decided by T_{JMAX} , θ_{JA} , and environment temperature (T_A). The maximum power dissipation is the lower one between $P_{DMAX} = (T_{JMAX} - T_A) / \theta_{JA}$ and the number listed in the maximum table.

Note 3: Human Body mode, 100pF capacitor discharge on 1.5K Ω resistor.

Recommended Operation Conditions

Symbol	Parameter	Input voltage	Range	Unit
I_{LED1}	Output LED current @ $V_{out}=36V_{dc}$	90Vdc~265Vdc	<250	mA
I_{LED2}	Output LED current @ $V_{out}=72V_{dc}$	90Vdc~265Vdc	<180	mA

Electrical Characteristics (Notes 4, 5) (Unless otherwise specified, $V_{CC}=12V$ and $T_A=25^\circ C$)

Symbol	Parameter	Conditions	Min	Typ	Max	Units
Supply Voltage Section						
V_{CC_ON}	VCC Turn On Threshold	V_{CC} Rising		11.2		V
V_{CC_HIGH}	VCC charging over Threshold Voltage	V_{CC} Rising		11.2		V
V_{CC_UVLO}	V_{CC} Turn Off Threshold	V_{CC} Falling		7.4		V
V_{CC_CLAMP}	V_{CC} Clamp Voltage			14		V
I_{CC_UVLO}	V_{CC} Startup Current	V_{CC} Rising, $V_{CC}=V_{CC_ON}-1V$		50		μA
I_{CC}	V_{CC} Operating Current	$F_{OP}=7kHz$		170		μA
Feedback Section						
V_{FB_FALL}	FB Falling Edge Threshold Voltage	FB Falling		0.2		V
V_{FB_HYS}	FB Hysteresis Voltage	FB Rising		0.15		V
V_{FB_OVP}	FB Over Voltage Protection Threshold			1.7		V
T_{ON_MAX}	Maximum On Time			5.7		μs
T_{OFF_MIN}	Minimum Off Time			2.5		μs
T_{OFF_MAX}	Maximum Off Time			150		μs
Current Sense Section						





JH5442IL7

V _{CS_LIMIT}	CS Peak Voltage Limitation			1.5		V
T _{LEB_CS}	Leading Edge Blanking Time for Current Sense			300		ns
T _{DELAY}	Switch off Delay Time			200		ns
Compensation Section						
V _{REF}	Internal Reference Voltage		194	200	206	mV
V _{COMP_LO}	COMP Low Clamp Voltage			1.65		V
V _{COMP}	COMP Linear Operating Voltage Range		1.65		4.45	V
V _{COMP_HI}	COMP High Clamp Voltage			4.45		V
Power MOSFET Section						
R _{DS_ON}	Static Drain-source On-resistance	V _{GS} =10V/I _{DS} =0.4A		7.0		Ω
BV _{DSS}	Drain-Source Breakdown Voltage	V _{GS} =0V/I _{DS} =250uA	650			V
I _{DSS}	Power MOSFET Drain Leakage Current	V _{GS} =0V/V _{DS} =600V			1	μA
HV JFET Section						
I _{JFET}	JFET Current	40V Between JFET Drain and Chip GND		9		mA
BV _{DSS}	JFET Breakdown Voltage		700			V
I _{DSS}	JFET Off Current			45		μA
Thermal Regulation Section						
T _{REG}	Thermal Regulation Temperature			142		°C

Note 4: production testing of the chip is performed at 25 °C.

Note 5: the maximum and minimum parameters specified are guaranteed by test, the typical value are guaranteed by design, characterization and statistical analysis





JH5442IL7

Application Information

The JH5442IL7 is a high precision Active PFC driver integrating 650V power MOSFET, specially designed for non-isolated buck offline constant current LED lighting. Operating in critical conduction mode, the driver achieves high power factor, low THD and high efficiency.

1 Start Up

The JH5442IL7 built-in JFET start-up and IC power supply circuit, the VCC power supply resistors and power feedback circuits from LED chips are not needed. After system power up, the VCC pin capacitor is charged up by JFET start-up and IC power supply circuit. When the VCC pin voltage reaches the turn on threshold, the internal circuits start working.

The COMP pin voltage is pulled up to 1.65V quickly, the JH5442IL7 starts switching then. The system works at 7kHz frequency at the beginning, the COMP voltage rises up gradually, and the inductor peak current also rises up. The LED current hence achieves a soft start without overshoot.

When the VCC voltage is higher than V_{CC_HIGH} , turn off the JFET, stop charging. When the VCC voltage is lower than V_{CC_on} , open the JFET, restore the charging.

2 Constant Current Control

The JH5442IL7 utilizes floating ground structure. The inductor current is sensed during the whole switching cycle, thus it achieves high precision output current control and also excellent line and load regulation.

The current in LED can be calculated by the equation:

$$I_{OUT} \approx \frac{V_{REF}}{R_{CS}}$$

Where,

V_{REF} : Internal reference voltage, typically 0.2V

R_{CS} : The current sensing resistor value

Also the JH5442IL7 will drop the output current to limit the temperature when the AC input voltage drop too much, the output current curve is show as below fig.for $V_o=54V$, $I_o=150mA$ application.The curve depends on the duty-cycle and the frequency, which could be change by L_p setting. Suggest $B_{max} < 0.26$.

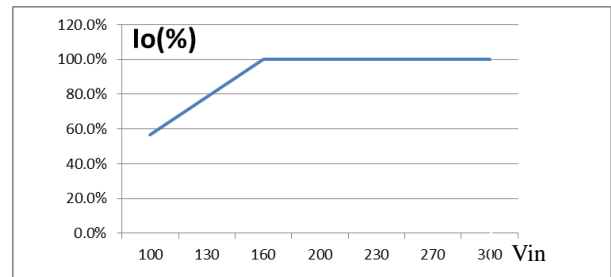

3 Feedback Network

The JH5442IL7 senses the output current zero crossing information through the feedback network, the FB falling threshold voltage is set to 0.2V with 0.15V hysteresis. The FB pin is also used to detect output OVP, the threshold voltage is 1.7V. The ratio of FB upper resistor to lower resistor can be set as:

$$\frac{R_{FBL}}{R_{FBL} + R_{FBH}} = \frac{1.7V}{V_{OVP}}$$

Where,

R_{FBL} : The lower resistor of the feedback network

R_{FBH} : The upper resistor of the feedback network

V_{OVP} : Output over voltage setting point





JH5442IL7

4 Thermal Regulation

The JH5442IL7 integrates thermal regulation function. When the system is over temperature, the output current is gradually reduced; the output power and thermal dissipation are also reduced. The system temperature is regulated and the system reliability is improved. The thermal regulation temperature is set to 142°C internally.

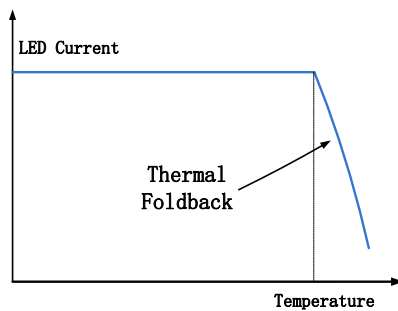

5 Protection Functions

The JH5442IL7 offers rich protection functions to improve the system reliability.

When the LED is open circuit, the output voltage will gradually rise up. The output voltage is sensed by the FB pin when power MOSFET is turned off. When FB voltage reaches the OVP threshold, it will trigger fault logic and the system stops switching.

After the system enters into fault condition, the VCC voltage will decrease as the internal IC power supply circuit stopping charging the VCC, until it reaches UVLO threshold. Then the system will restart again. If the fault condition is removed, the system will resume normal operation.

When the LED is shorted circuit, the switching frequency will work under 7 kHz. Meanwhile, the output voltage is low and the VCC pin cannot be charged up by the output voltage, so the VCC pin voltage will gradually decrease and finally reaches the UVLO threshold.

When the output is short circuit or the inductor is

saturated, the CS peak voltage will be relatively high. When CS voltage reaches the internal limitation (1.5V), the power MOSFET will be turned off instantaneously. This cycle by cycle current limitation can help protecting the power MOSFET, the inductor and the output diode.

6 PCB Layouts

The following guidelines should be followed in JH5442IL7 PCB layout:

Bypass Capacitor

The bypass capacitor on VCC pin should be as close as possible to the VCC and GND pins.

Ground Path

The power ground path for current sense resistor should be short and wide, and it should be as close as possible to the IC ground (GND), otherwise the LED output current accuracy maybe affected. The IC signal ground should be individually connected to the IC GND pin .

The Area of Power Loop

The area of main current loop should be as small as possible to reduce EMI radiation.

FB Pin

The feedback resistor divider should be as close as possible to the FB pin, and the trace must keeps away from dynamic node of the inductor (DRAIN pin trace), otherwise the FB pin OVP function might have risk to be mis-triggered by the system noise.





JH5442IL7

Physical Dimensions SOP-7

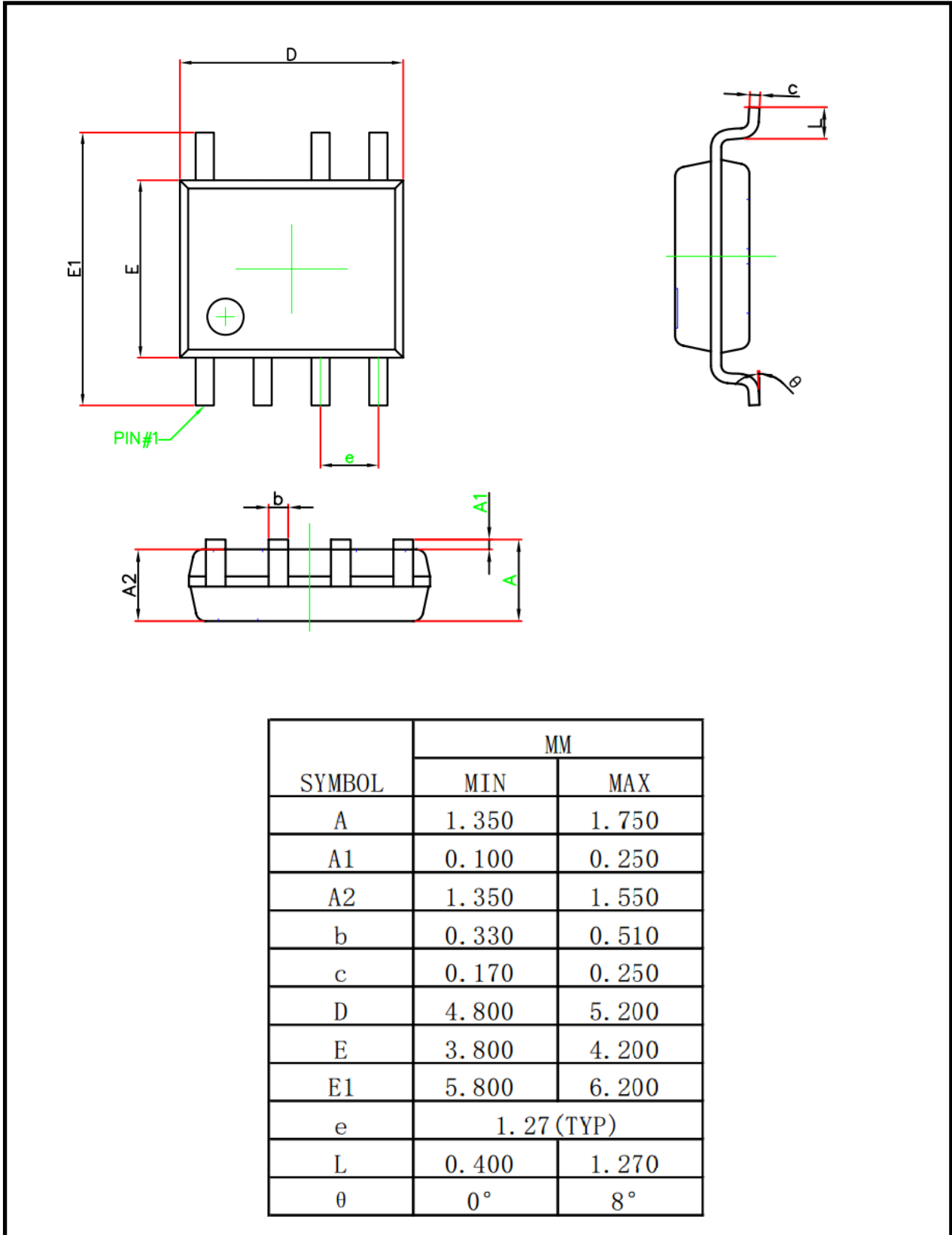



JH5442IL7

注意事项

1. 吉林华微电子股份有限公司的产品销售分为直销和销售代理，无论哪种方式，订货时请与公司核实。
2. 购买时请认清公司商标，如有疑问请与公司本部联系。
3. 在电路设计时请不要超过器件的绝对最大额定值，否则会影响整机的可靠性。
4. 本说明书如有版本变更不另外告知。

NOTE

1. Jilin Sino-microelectronics co., Ltd sales its product either through direct sales or sales agent, thus, for customers, when ordering, please check with our company.
2. We strongly recommend customers check carefully on the trademark when buying our product, if there is any question, please don't be hesitate to contact us.
3. Please do not exceed the absolute maximum ratings of the device when circuit designing.
4. Jilin Sino-microelectronics co., Ltd reserves the right to make changes in this specification sheet and is subject to change without prior notice.

联系方式

吉林华微电子股份有限公司

公司地址：吉林省吉林市深圳街 99 号

邮编：132013

总机：86-432-64678411

传真：86-432-64665812

网址：www.hwdz.com.cn

市场营销部

地址：吉林省吉林市深圳街 99 号

邮编：132013

电话：86-432-64675588

64675688

64678411-3098/3099

传真：86-432-64671533

CONTACT

JILIN SINO-MICROELECTRONICS CO., LTD.

ADD: No.99 Shenzhen Street, Jilin City, Jilin Province, China.

Post Code: 132013

Tel: 86-432-64678411

Fax: 86-432-64665812

Web Site: www.hwdz.com.cn

MARKET DEPARTMENT

ADD: No.99 Shenzhen Street, Jilin City, Jilin Province, China.

Post Code: 132013

Tel: 86-432-64675588

64675688

64678411-3098/3099

Fax: 86-432-64671533

